

Aquiba A200

Residential smart water meter

Datasheet

Product overview

Aquiba's A200 DN20 residential smart water meter offers world beating metrology and excellent product durability, with no wear or jamming. It is a flexible and future-proof platform for smart metering and intelligent water networks.

A200 consists of a highly accurate mag-flow sensor, powerful processor and a data archive. The sensor technology, considered the gold standard in water metering, accurately measures flow at all flow rates relevant to revenue collection. The processor stores time-stamped readings in the archive and can run additional applications in real time to convert high volumes of data into discrete items of information. Data can be extracted via the optical port and certain information can be retrieved by radio (as supported by bi-directional ZigBee SEP 1.0, included in A200-Z).

A200 is fully compliant with NMI R49:1 Class 2 (Certificate of Approval NMI 14-3-16) and AS/NZ 4020:2005 (Certificate of Approval PST25423) and is approved for use in Australia.

Key benefits and features

Better meter

- Fully static mag-flow technology
- Accurate at all flow rates, over full service life
- No moving parts – no wear or jamming
- Eliminates under-registration issue
- High resolution, time-stamped data securely stored in data archive
- Low lifetime cost and low environmental impact
 - 15 year battery life
 - Factory refurbishable for extended operation
- Supports network and household leakage detection
- No registration of air

Smart Meter

- Secure ZigBee SEP 1.0 radio
- Future proof
 - Field upgradeable firmware
 - Generous processor and memory capacity for additional applications

Optical interface

The A200's secure optical port allows connection of an optical reader programmer (ORP) for easy programming and data retrieval. The ORP simply clips onto the top of the meter and is held in place by magnets. Data is transferred via USB cable to a PC running Aquiba Meter Explorer software.

This software enables installation, configuration, commissioning and maintenance of the A200. It also performs basic data visualisation and allows consumption data to be exported to third party applications for additional analysis.

See Application Note "Evaluating Aquiba's A200 Water Meter".

System functionality

The A200 smart water meter is not just a cash register for billing purposes. It can also provide useful data for many other parts of the water company's business and its customers.

See brochure "Getting the best from the A200 meter" for an overview of potential opportunities.





A200 Specification

Item	Unit	Value	Comment
Nominal Diameter		DN20	

Metrology and R49 compliance			
Measurement technology		Electromagnetic	
Starting flow rate (approx)	m ³ /h	0.0035	
Leakage detection (approx)	m ³ /h	0.0001	Averaged over 8 hours. Not registered
Minimum flow rate	Q1	m ³ /h	0.016
Transitional flow rate	Q2	m ³ /h	0.026
Maximum flow rate	Q3	m ³ /h	4
Overload flow rate	Q4	m ³ /h	5
Measuring range (R)	Q3/Q1		250
Max working pressure	MPa		1.4
Pressure loss @Q3	MPa		0.025
Ambient temperature	°C		0 to 60
Meter temperature class			T30
Ambient humidity range	%RH		0 to 100
Installation positioning			any
UV exposure resistant			Exceeds AS3565.1 (pt3.3)
Minimum registration (LCD)	litre		0.05
Minimum registration (internal)	litre		0.01
Maximum registration	m ³		99999.99995

Battery			
Battery life	Years	15	Depending on radio usage and temperature
Battery life indication		Dynamic	Based on actual usage and temperature history

Communications			
Integrated radio (A200-Z)			ZigBee 2.4GHz Smart Energy Profile 1.0 – all mandatory clusters
Integrated optical port			Bi-directional

* Over the air (OTA) upgrade is an optional feature of SEP and will not be supported by first models of the A200-Z. A200-Z may be later upgraded to support OTA upgrade using the Optical Reader / Programmer.



Item	Unit	Value	Comment
Data archive			
Memory size	Mbyte	1.5	Approx 800,000 samples with included data compression algorithms
Data sources		Billing register value (resolution 0.01 litre) Raw consumption (resolution 0.001 litre) Internal temperature (resolution 1°C)	
Sample interval minimum	seconds	5	
Time-stamped alerts		Reverse flow, magnetic tamper, battery tamper, empty pipe (recorded in engineering log and accessible via optical port)	

Mechanics			
Housing construction		Engineering polymer	
Water and dust protection		IP68	
Frost resistant		Yes	
Threaded connection		G1B or to local standard	
Torque resistance of thread	Nm	>95	
Weight (approx.)	g	500	
Inlet strainer		Optional	

Dimensions

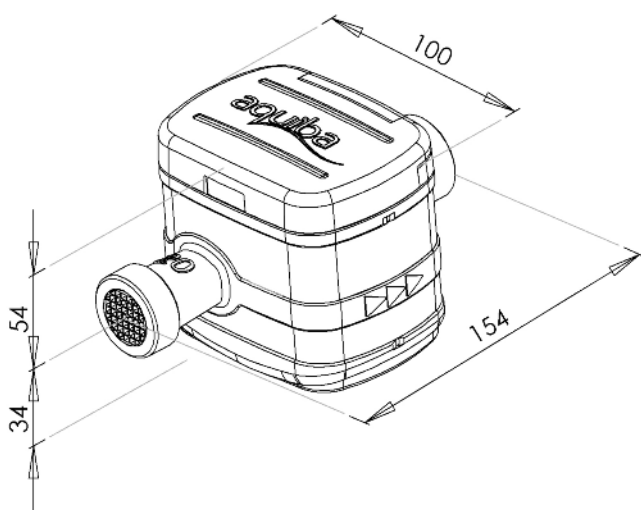

Installation requirement

Where the supply pipe may be used as an electrical earth, A200 must be installed with permanent electrical cross bonding.

Compliance with AS3565.1:2010

The A200 does not have an integral check valve and therefore cannot be approved to AS3565.1-2010. A200 has been designed and tested by Aquiba for compliance with all other requirements of this standard including:

- Dimensions
- Ultraviolet exposure
- Material durability tests (Cyclic Temperature and Pressure)
- Torque resistance
- Watertightness



N28621

Aquiba is a joint venture of Sentec Ltd, UK and Takahata Precision Co. Ltd, Japan.

For more information please contact us:

Australia: **+61 (0)7 5450 2751**

UK: **+44 (0)1223 303800**

